

Getting Going on Digimodes

*A personal & practical
perspective by*

Pat McGuinness G4FDN



Synopsis

- What are digimodes? Why operate?
- A brief history (incomplete)
- Atypical digimode TX/RX system
- The role of the PC and soundcard
- The radio - soundcard interface
- Software: Digipan as an example
- Setting up procedures
- Bandplans - where the activity is
- Live demo (conditions permitting)
- Questions & answers

What are digimodes?

- Any mode that uses a machine or computer in the generation and detection of the signal typically taking input from a keyboard and presenting output to a VDU.
- **Examples:** RTTY, PSK31, Packet, AmTOR, PacTOR, MFSK16, Clover, FSK441
- *Is CW a digimode?*

Why operate?

- Wanted to try something new
- Attracted by weak signal performance and portable, QRP and DX capabilities
- Good QSO's possible with small antennas
- Family friendly - can be operated while others are watching TV or reading in same room
- Learn about DSP capabilities of soundcard
- Learn more about HF propagation

A Brief History (incomplete)

- **First digimode was probably Cooke & Wheatstone's telegraph in 1837**
- **David Hughes: synchronous direct printing telegraph in 1845**
- **Donald Murray in 1900's: tape reader & keyboard perforator**
- **Teletype Corp in 1920's**
- **RTTY as we know it from 1940's**
- **AmTOR by G3PLX in 1978**
- **PSK31 by G3PLX in 1998**
- **FSK441 by K1JT in 2000**

Cooke & Wheatstone Telegraph

This machine sent messages between Paddington and Slough to help the railway run smoothly. In 1845 it relayed the description of a murderer, who was arrested as he disembarked.



Creed 3X teleprinter



The 3X prints on narrow gummed paper tape, and was introduced in 1927 for the GPO Telegram service. The standard signalling speed was 49 Bauds using the Murray code

A modern amateur digital station



The station of Dave KB5WIA

The main elements of a typical digital station

- **AHFSSBtransceiverand/orVHF/UHFFM transceiver**
- **Acomputer,typicallyrunningWindows 95orlater,Linux,orAppleMacoperating system, -usuallywithasoundcard**
- **Applicationsoftwareforthe particular mode**
- **Aradiotocomputerinterface -maybe simpleorcomplex,i.e.simple:audio couplingandPTTcontrol;complex:e.g. TNCormulti -modecontroller**

A closer look at system requirements for PSK31

- PC: with a 486/Pentium processor (100MHz min), 32MB RAM, 200MB hard disk, Windows 95 or later, 16bit soundcard
- HFSSB Txcvr with stable VFO or Xtal
- Radio - PC soundcard interface with leadsto connect with the transceiver and the PC soundcard - homebrew or buy
- PSK31 software: Digipan, WinPSK, etc



The role of the PC and soundcard

- The PC screen and keyboard act as the man-machine interface
- The soundcard together with the application software and OS forms the audio modulation - demodulation sub-system using DSP

Radio - Soundcard Interface Functions

- **Separation(isolation)ofgrounds betweenPCandRadio**
- **Couplingofaudiofrom/tosoundcard to/fromradio**
- **Audioleveladjustment**
- **PTTcontrolofradioviaPCCOM(serial) port**
- **VisualindicationofTX/RXstate(LED)**
- **Connectionleadstosuitradio**

Typical Audio Levels & Impedances

- Radio Mic socket: tensofmV, 600to50K
- Radio Spkr socket: 1to10V, 4to16R
- RadioDatsocket: 0.1to0.5V, 1Kto10K
- Soundcard Micskt : 0.01to0.2V, 600to2K
- SoundcardLineIn: 0.1to0.7V, 20Kto50K
- SoundcardLineOut: 0.1to0.7V, 100Rto2K
- Soundcard Spkrskt : 1to5V, 4Rto8R

Typical Radio - Soundcard Interface

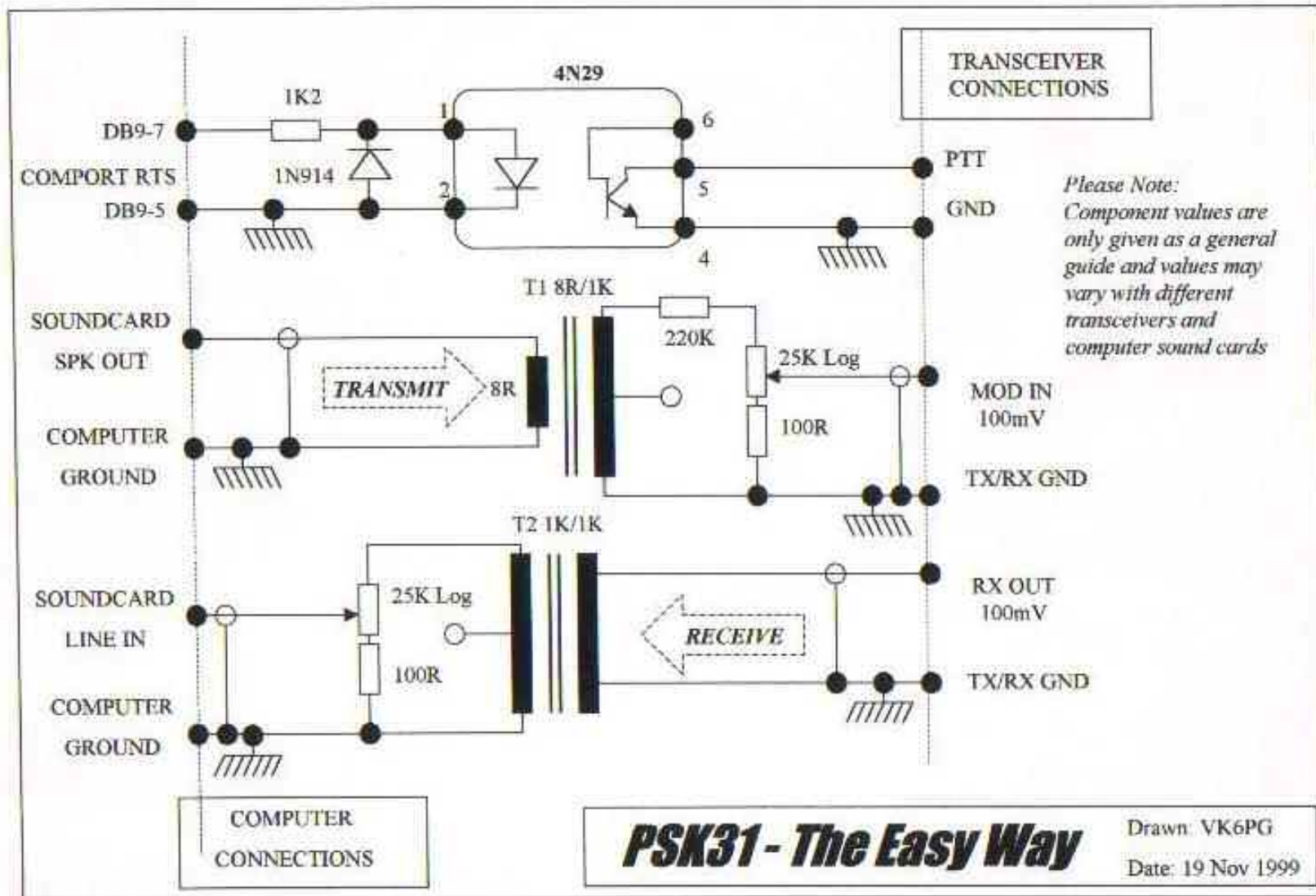

Interface - Build or Buy?

- Build: component cost less than £10 new - Verobor perf boards sufficient
- Buy: £30 to £200!





Digimode application software

- ***FreeorBuy?***
- Free: Digipan, Stream, WinPSK
- Buy: MixW2, TrueTTY, Hamscope



Digipan

- Digital Panoramic Tuning

- *a watershed in improving the ease and convenience of seeing, tuning, and making PSK31 contacts 'point & click'*

Up until Digipan appeared all tuning relied on a phase scope



Setting Up & Adjustments

- Audi input to Tx must be low enough not to operate ALC
- Tx power must be kept lower than for SSB because of high duty cycle
- This usually means a maximum power of 25 to 35 W for a nominal 100 W SSB Tx cvr



Bandplans -where the activity is

- 20m 14.070MHz
- 10m 28.120MHz
- 15m 21.070MHz
- 80m 3.580MHz
- 30m 10.139MHz
- 40m 7.035MHz
- 12m 24.920MHz



Some stations worked on PSK31

UA9NOLY2XZS57LPL9A5ABH

CU3CZEU4AC3Z0AKYL2CS

ES7AMZ36AK5DNLLU9EVL

ER3ZZUN0BN1QLZTA2ESVE9DX

LZ2NP4X1AJSV1CAXSN0ZS

CX5ABMLU3EAPW4GTM

***-using 25W & a 3m long dipole 4m
above ground in Carshalton***

Some Useful URL's

As a follow-up to my Digimodes presentation here is a list of relevant URL's. The first one is very interesting and useful it is a PSK31 receiver in Germany many on 14.070 - so can be used to check your own transmissions. Only problem is that it appears to be very busy as I have only been able to connect to it once.

PSK31 Receiver Portal - monitor your PSK31 on 20m signal via the internet!

<http://www.hamradio-portal.com/psk/start.html>

PSK31 Official Homepage <http://www.aintel.bi.ehu.es/psk31.html>

PSK31 Soundcard Interfaces and diagrams <http://www.packetradio.com/psk31.html>

WM2U's PSK31 page <http://www.qsl.net/wm2u/psk31.html>

ARRL articles on PSK31 <http://www.arrl.org/tis/info/psk31.html>

MFSK16 A new weak signal DX mode <http://www.qsl.net/zl1bpu/MFSK/>

MFSK16 vs PSK31 Ionospheric Simulation <http://home.teleport.com/~nb6z/compare1.htm>

ARRL articles and links on digital modes <http://www.arrl.org/tis/info/digital.html>

Amateur Radio Digital Modes Software <http://www.packetradio.com/software.htm>

FSK441 & WSJT - explanation of mode and supporting software

<http://www.vhfdx.de/wsjt/fsk441.htm>